

MOST MHP 3-axis hydraulic positioner

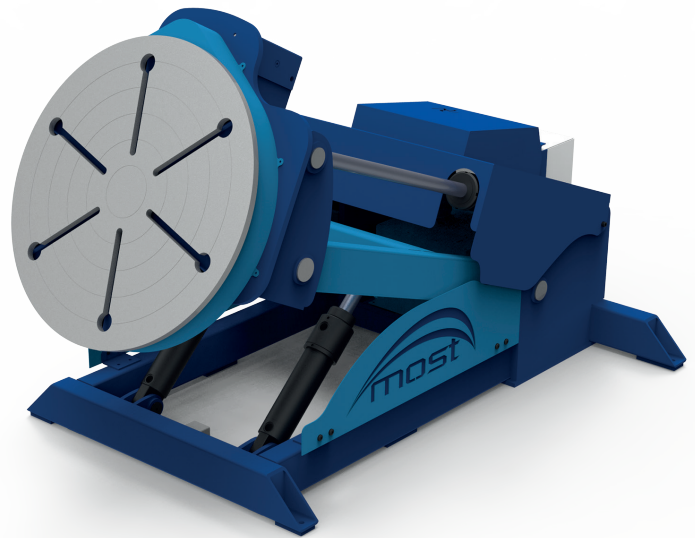

In welding work, positioners are convenient aids in increasing working flexibility, productivity and quality, not to mention labor motivation. Flexible to move work to any suitable position, what allows work-pieces to be set up to the best possible down-hand welding positions.

3-axis positioners MOST series MHP are equipped with adjustable rotation, tilting and height movement functions. Possibility for stepless 3-axis work-piece adjustment guarantees ideal, productive and ergonomic work positions. Inverter-controlled AC-driven rotations are smooth and accurate in all loading conditions. Powerful, hydraulically-operated tilting and height adjustments enable safe positioning of work-pieces into optimum welding and working positions.



Positioners with loading capacity up to 5000 kg (other various capacities available upon request).

- Positioners are equipped with:
- 3-axis hydraulic system,
- remote controller with 5 meter cable,
- digital speed indicator on the controller panel for monitoring rotation,
- motors with brake and forced fan cooling.

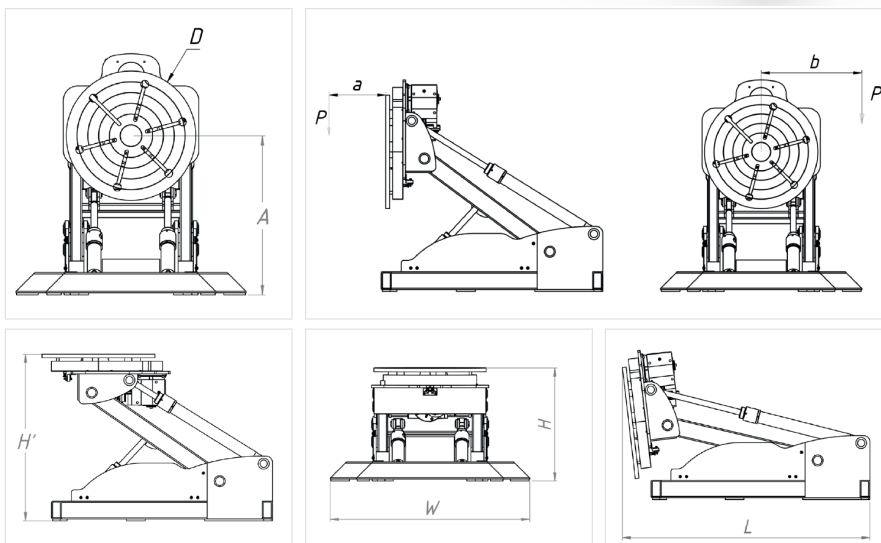
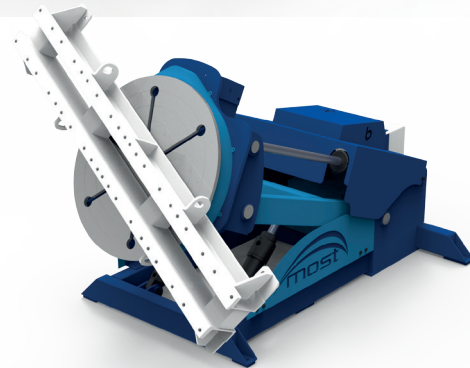

Model	Rated load capacity	Table diameter	Max. height with horizontal table [mm]	Max. height with vertical table	Min. height with vertical table [mm]	Length overall [mm]	Max. height [mm]	Table rotation speed [min/max-rpm]	T-Slots [°]	Table motor power [kW]	Rotation torque [Nm]	Motor power of hydraulic unit [kW]	Weight [kg]
		[mm]	A	H'	H	L	W						
MHP-05	0,5	800	930	1650	930	1700	850	0,14 / 1,4	5-72	0,55	2050	0,75	975
MHP-1	1	850	930	1650	930	1900	920	0,14 / 1,4	5-72	0,55	2350	1,1	1050
MHP-2	2	900	1100	1360	910	1990	1600	0,14 / 1,4	5-72	0,75	5000	2,2	1300
MHP-3	3	1050	1950	1950	1050	2275	1980	0,14 / 1,4	5-72	1,10	10500	3	2350
MHP-5	5	1200	1700	1900	1150	2500	1500	0,14 / 1,4	5-72	1,1	15180	4	2700