

Chain manipulators MOST MCHR



Chain manipulators allow to lift and rotate long objects, such as heavy sections, booms and other space structures, with no need of gantry crane use. Maximum load capacity up to 20 t, width of work-piece up to 2500 mm. The solid construction and resistance to sharp edge of the welded parts, allow to weld and grind in the most suitable position.

Simple operation and work ergonomics greatly improve productivity and quality of the production processes. These units are equipped with:

- remote controller with 5 meter cable,
- digital rotation speed display.

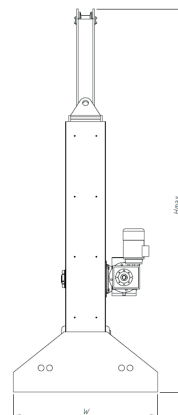
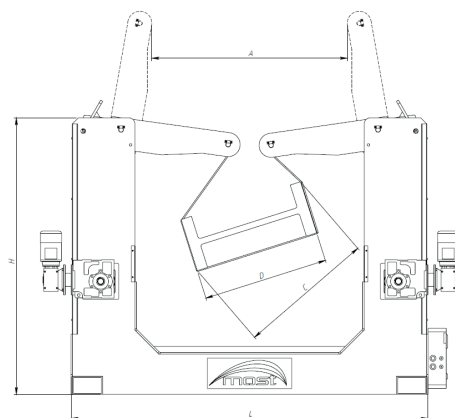
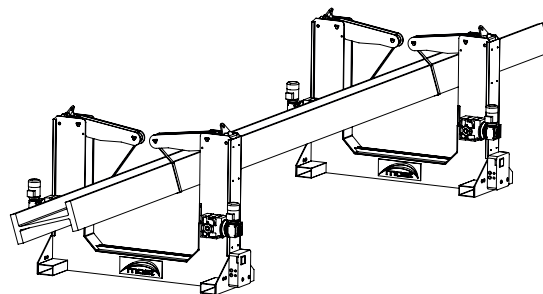
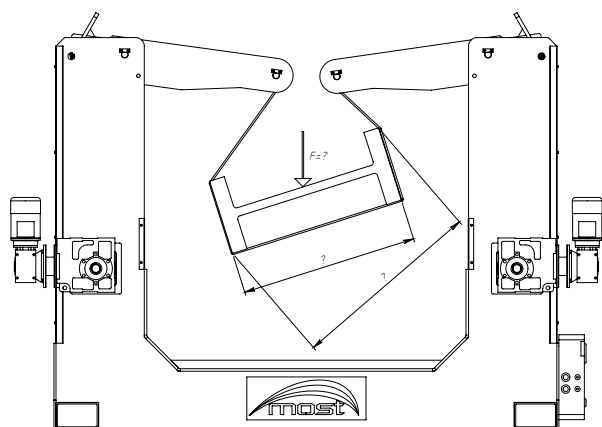

Model	Capacity [t]	Rotation speed [mm/min]	Work-piece width [mm]	Operating width [mm]	Base overall length [mm]	Base overall width [mm]	Height		Distance between rolls [mm]	Motor power [kW]	Voltage [V]
			D		L	W		Hmax			
MCHR-5	5	500-5000	600	[mm]	1600	800	1300	1750	750	4x1,1	400
MCHR-10	10	500-5000	1000	1450	2000	1000	1700	2450	1150	4x1,5	400
MCHR-15	15	400-4000	1200	1750	2750	1200	2100	3000	1350	4x1,5	400
MCHR-20	20	400-4000	1500	2150	3050	1500	2500	3600	1650	4x2,2	400